

WILDING WALLBEDS INSTALLATION INSTRUCTION

INSTRUCTION BOOKLET P-11-V

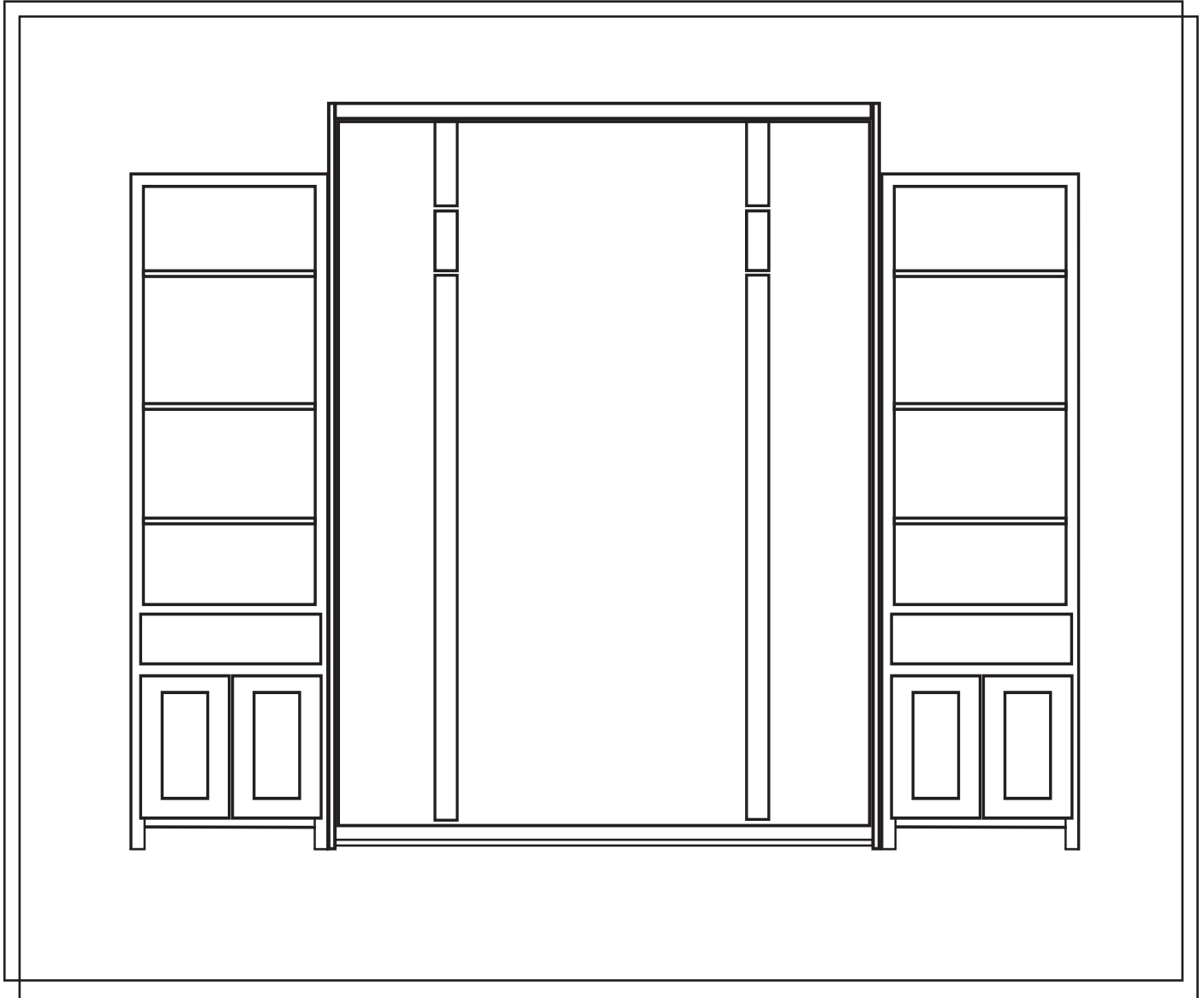







Watch video installation instructions at:

www.wallbedsbywilding.com/homefront-installation/

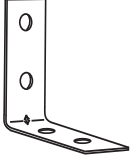
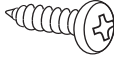



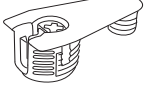
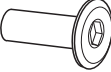
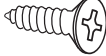
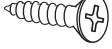
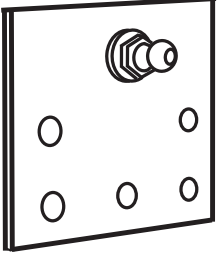
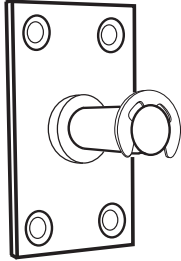

WARNING! ALL MURPHY/WALLBED SYSTEMS CONTAIN POWERFUL LIFTING COMPONENTS. FAILURE TO USE AND FOLLOW THESE INSTRUCTIONS DURING THE INSTALLATION PROCESS COULD RESULT IN SEVERE PERSONAL INJURY TO USER OR DAMAGE TO PRODUCT. PLEASE CONTACT CUSTOMER SERVICE AT 866-725-6401 FOR ANY QUESTIONS.

Rev. 12.19

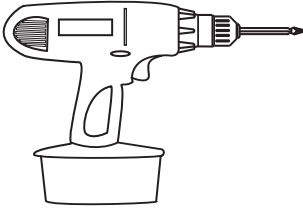
Hardware Supplied

 <p style="text-align: right;">QTY 3</p> <p>“L” Bracket</p>	 <p style="text-align: right;">QTY 6</p> <p>5/8” Pan head Screw</p>	 <p style="text-align: right;">QTY 17</p> <p>Connecting Bolt</p>
 <p style="text-align: right;">6</p> <p>3/16” Machine Screw</p>	 <p style="text-align: right;">6</p> <p>2.5” Wood Screw</p>	 <p style="text-align: right;">3</p> <p>Cam Fitting (extras)</p>
 <p style="text-align: right;">6</p> <p>3/16” Barrel Nut</p>	 <p style="text-align: right;">6</p> <p>#12 x 3/4” Zinc Screw</p>	 <p style="text-align: right;">8</p> <p>#8 x 3/4” Black Screw</p>
 <p style="text-align: right;">2</p> <p>Upper Anchor plate</p>	 <p style="text-align: right;">2</p> <p>Pivot Point</p>	 <p style="text-align: right;">2</p> <p>Bed Stop</p>

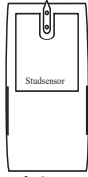
Tools Needed

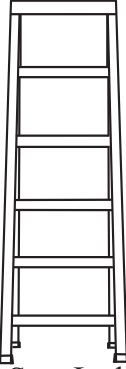
 <p>Cordless Screw Driver or Power Drill with Phillips bit</p>	 <p>Pliers</p>	 <p>Tape Measure</p>
 <p>3/16” wood drill bit</p>	 <p>Stud Sensor</p>	 <p>Small Regular Screw Driver</p>
		 <p>Phillips Screw Driver</p>
		 <p>6” Step Ladder</p>

Wall Bed Components

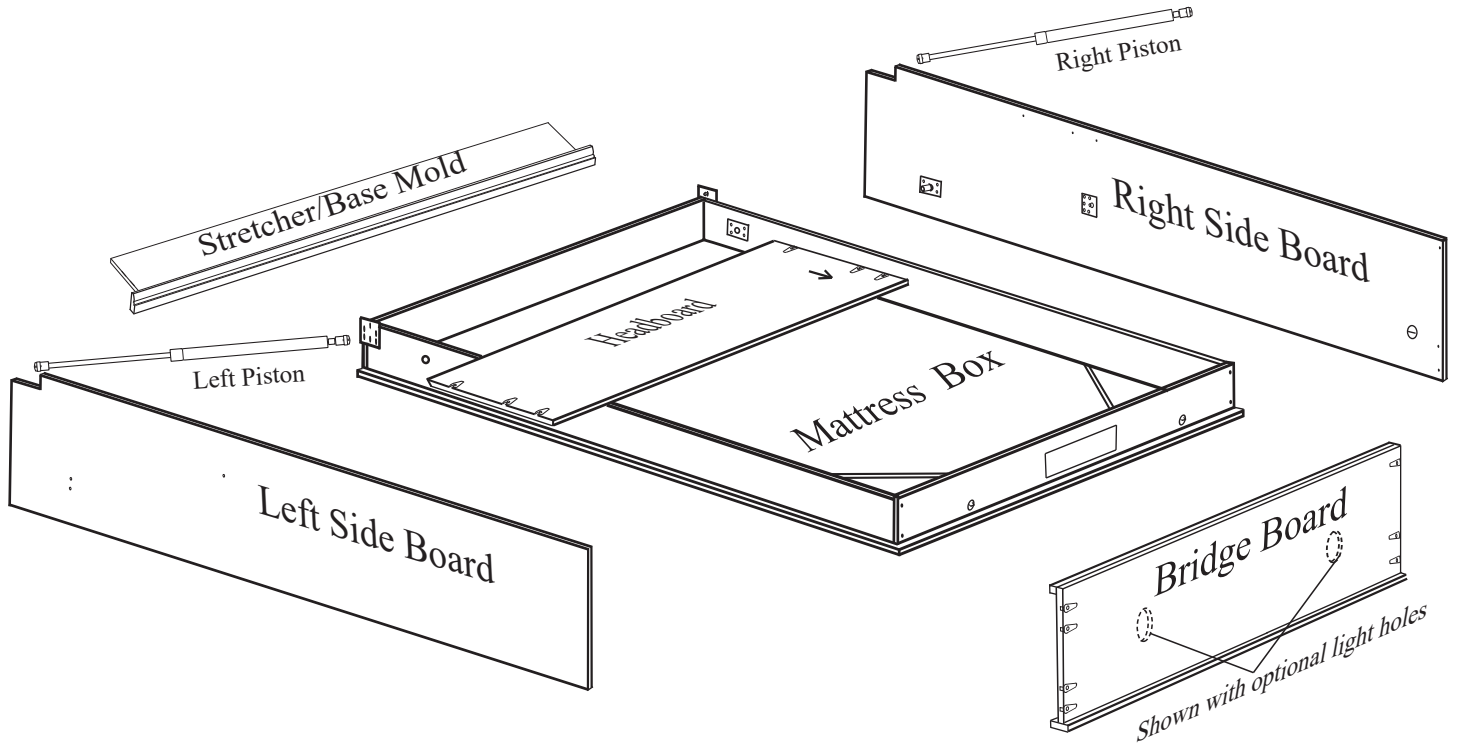

Hardware and parts needed for next step:

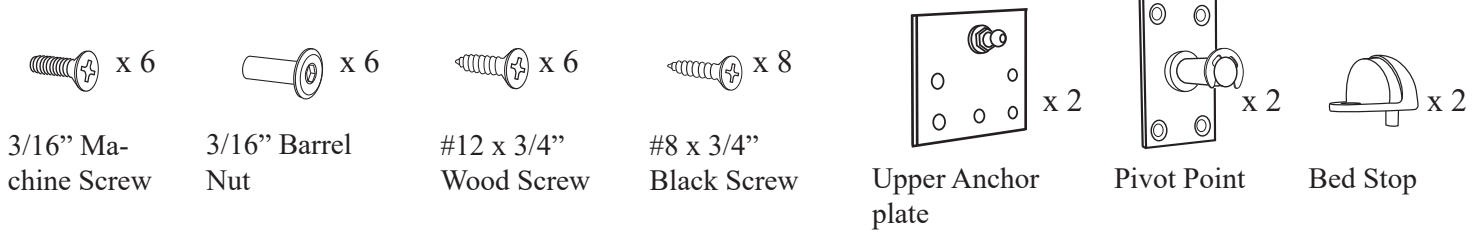

Step 1: Locate the left AND right Side Boards and install:

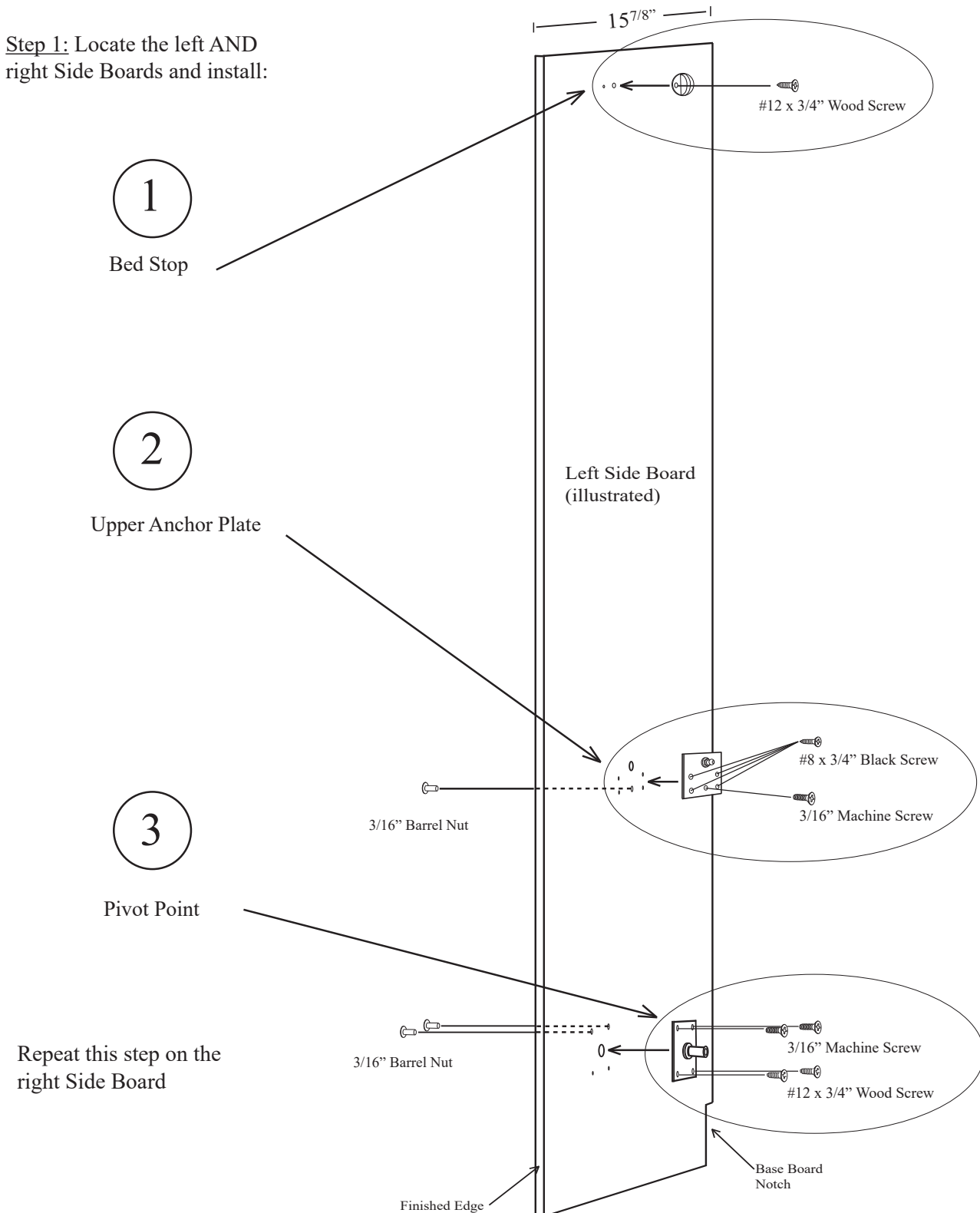

Hardware needed for next step:



Connecting Bolt

Step 2: Lay the right and left Side Boards down as illustrated and screw the Connecting Bolts into the holes provided as illustrated.

Note: Screw the connecting bolts down until the collar of the connecting bolt is seated firmly against the surface of the wood.

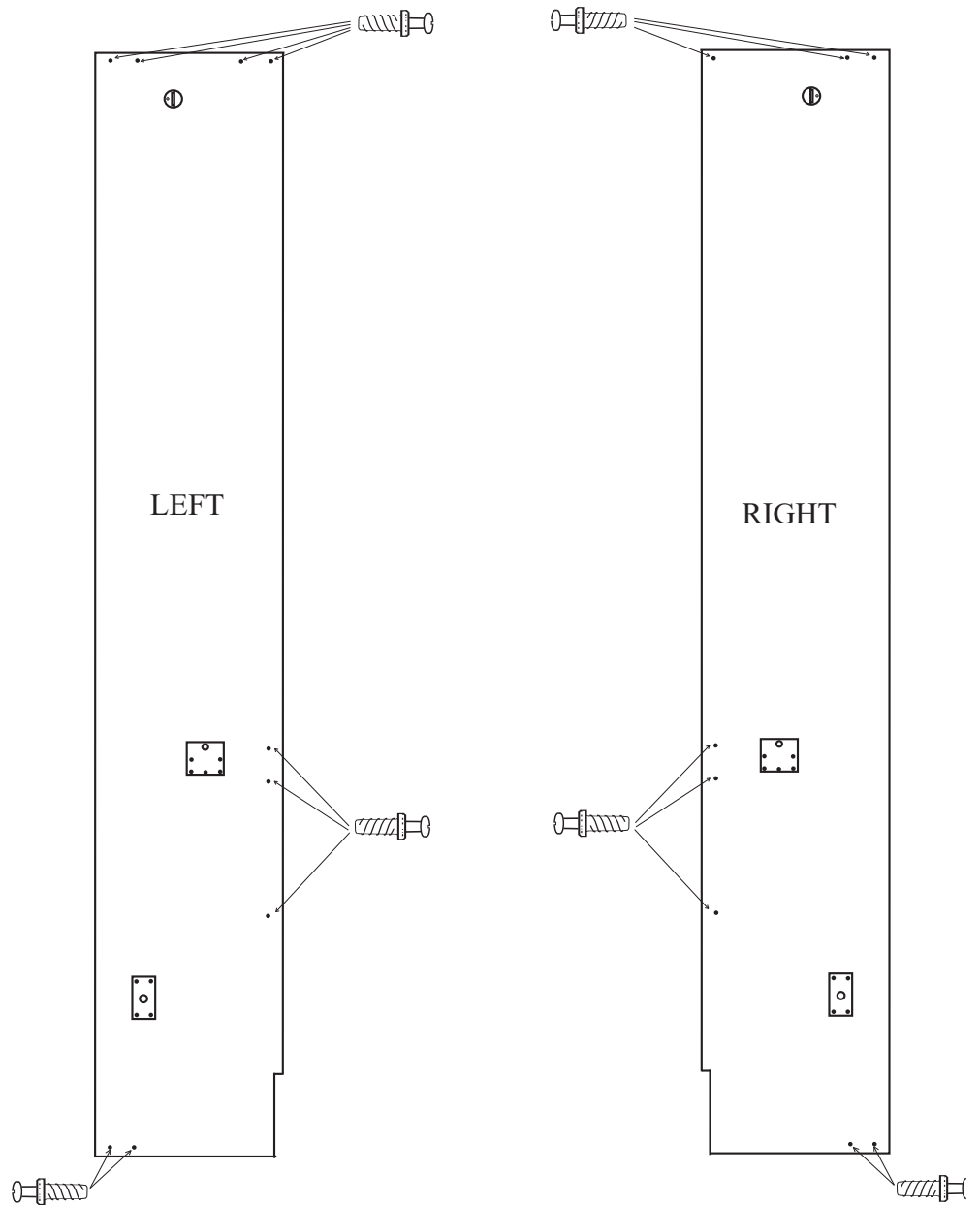
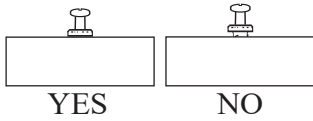

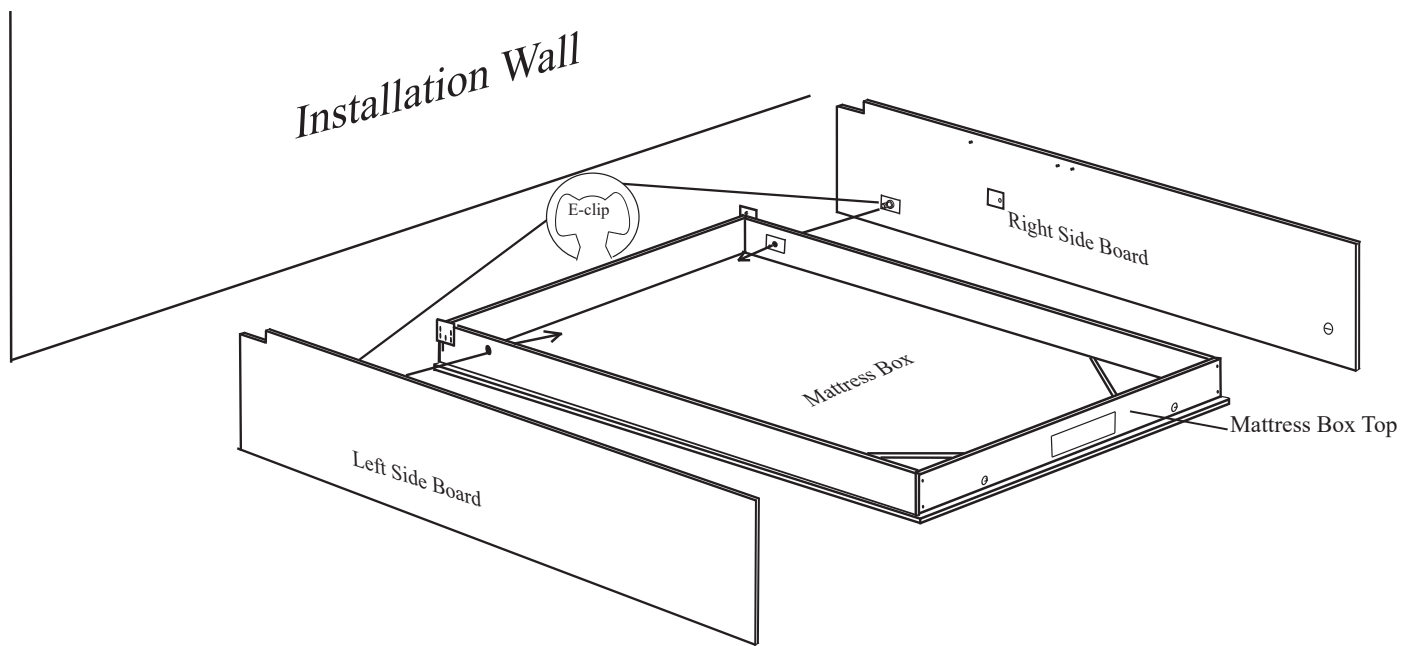

Step 3: Position the Mattress Box and the right and left Side Boards face down on the floor with the bottom of the Mattress Box approximately 2.5 feet from the wall where the bed will be installed.

Step 4: With a pair of pliers, remove the E-clips from the Pivot Posts on the Side Boards. Leave the white nylon spacers in place on the posts.

Step 5: Slide the Side Board pivot posts through the pivot holes in the Mattress Box as illustrated then replace the E-clips onto the pivot posts.

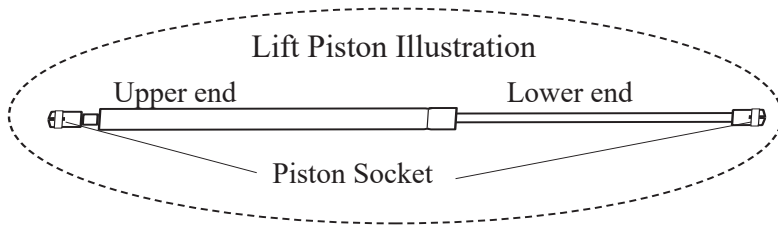

Step 6: Attach the lower end of the Lift Piston (skinnier end) onto the Lower Anchor Plate on the Mattress Box by positioning the socket of the piston directly over the ball stud on the anchor plate and pushing them on. The piston socket will snap into place over the ball. Repeat on the opposite side.

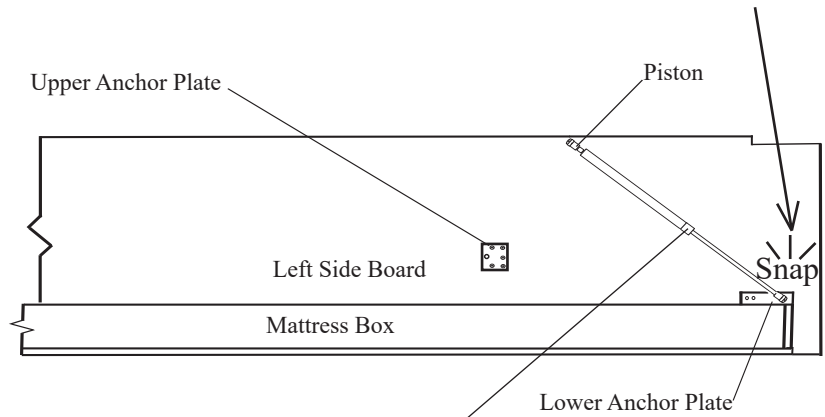

Step 7: Spread the Side Board tops so the Mattress Box has clearance to pass through the Bed Stops on the Side Boards. (Illustration 1)

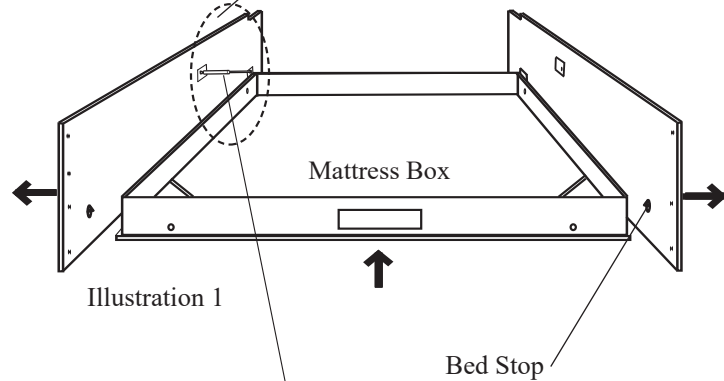

Step 8: This step will require two people. The first person will kneel down in front of the Mattress Box and lift it up about 4 to 5 inches while the second person positions the upper socket end of the Lift Piston directly over the ball stud on the upper anchor plate and snapping it into place. The first person will need to slightly raise and lower the Mattress Box to allow the Piston to line up and snap on. Repeat on the opposite side so both pistons are attached. (Illustration 2)

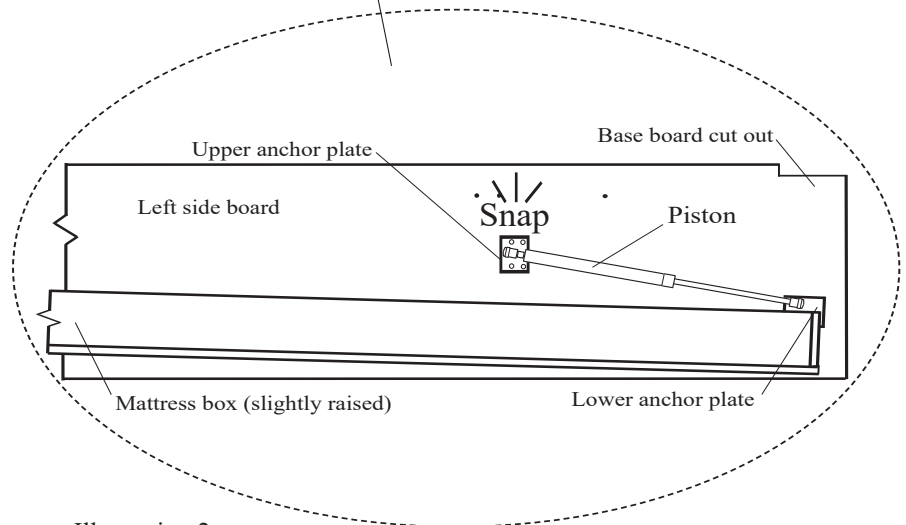

Step 9: Connect the Bridge Board to the Side Boards as illustrated. Tighten the Cam Fittings with a hand screw driver by turning the fitting clockwise one half turn . Do not use a power screw driver.

HELPFUL HINT: It is easier to engage the Bridge Board's cam fittings to the Side Boards if you (with your helper) raise the end of the Side Boards just above the Mattress Box. Raise both Side Boards at the same time as you fit the Bridge Board in place.

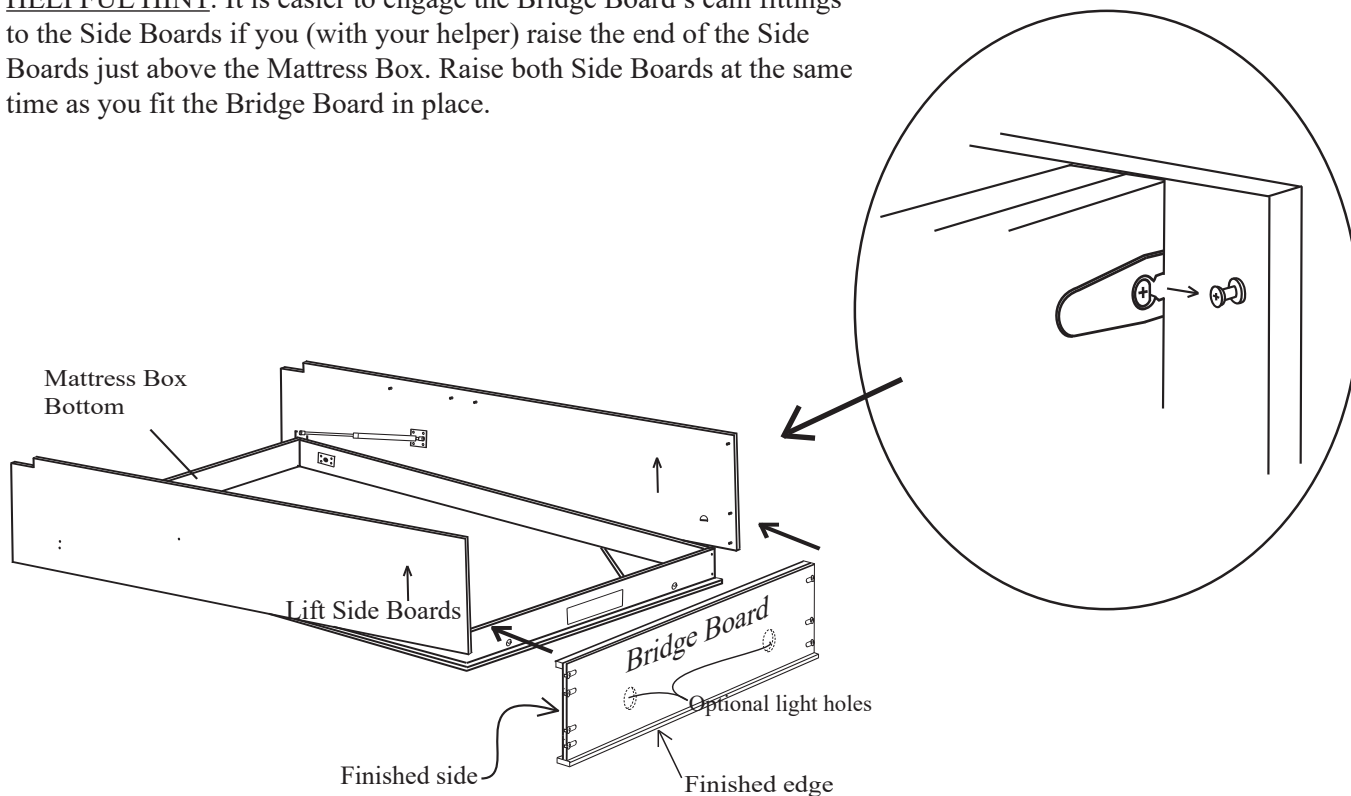

Step 10: With the bed unit still lying face down on the floor the Headboard can be installed. **HAVE SOMEONE HELP WITH THIS STEP.** Slide the Headboard between the Side Boards and under the Connecting Bolts to align it with the proper Connecting Bolts. Now with a Phillips screw driver tighten the Cam Fittings by turning them clockwise. Do this procedure should be done with hand screwdriver.

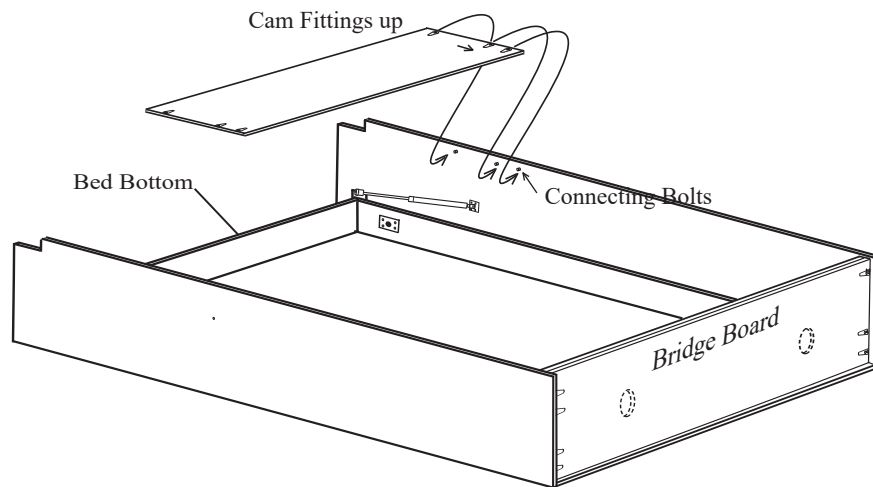

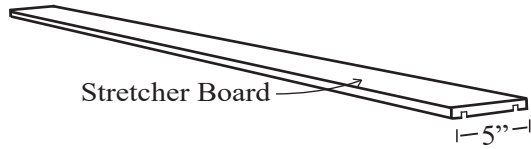

Step 11: Locate the Stretcher Board and slide it between the Side Boards at the bottom of the Wallbed unit. Insert the Connecting Bolts into the Cam fittings and tighten them by turning the cam clockwise.

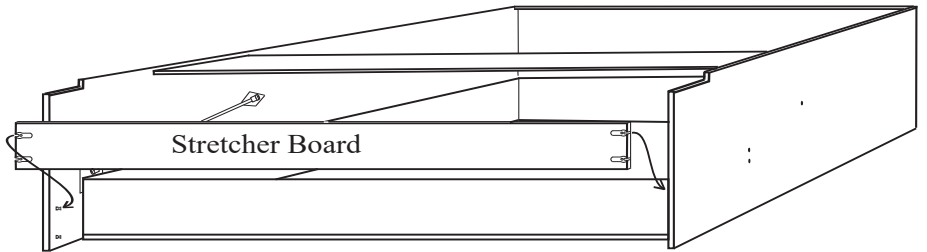

IF YOU PURCHASED A LIGHT KIT FOR YOUR WALL BED YOU MUST INSTALL LIGHT SYSTEM AT THIS POINT

Refer to instructions in the light kit box for installation

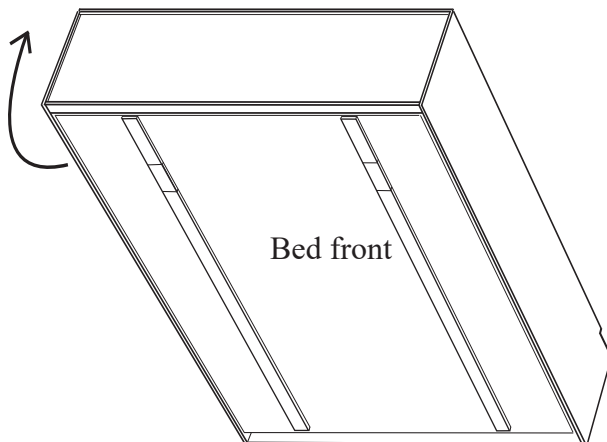

Step:12: This step will require 2 people. From the top of the Wall Bed unit lift it up to the standing position.

WARNING: The bed front is heavier and the Wall Bed unit may not stand on its own.

HEAVY TWO PEOPLE REQUIRED!

Step 13: Once the bed is standing, slide it back and position it against the wall where it is to be installed. Check the gap between the Side Boards and the Bed Front on both sides. The gap at this point will probably need to be adjusted. You can adjust the gap by pushing the bed cabinet to one side or the other at the top. Pushing it will even out the gap from top to bottom on each side.

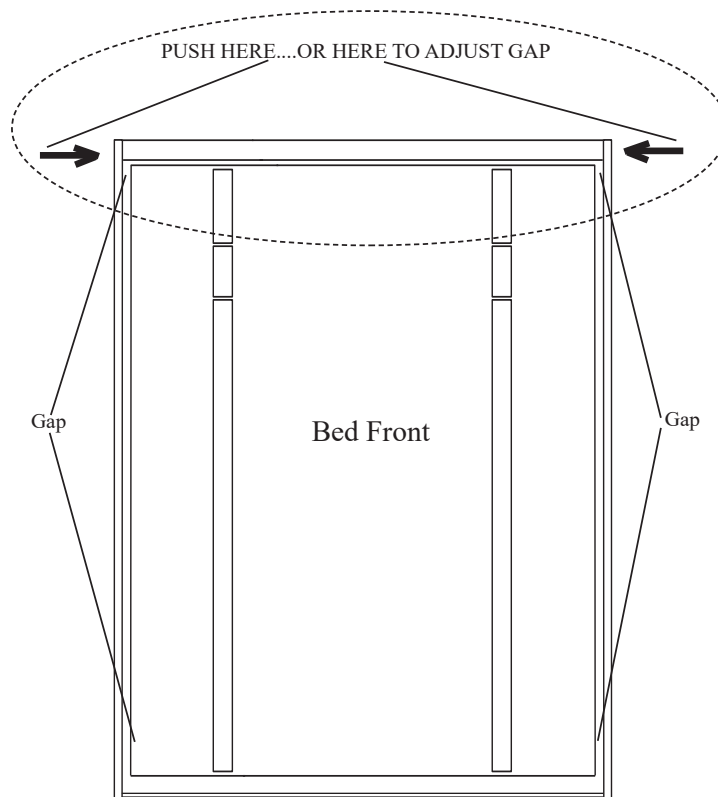

WARNING! THE NEXT STEP MAY REQUIRE PROFESSIONAL HELP.

IF YOUR WALLS ARE NOT TRADITIONAL WOOD FRAMING, YOU MAY NEED TO HIRE A HANDY-MAN OR CONTRACTOR TO HELP IN ANCHORING THE BED UNIT TO YOUR WALL. FAILURE TO PROPERLY ANCHOR THE BED CABINET COULD CAUSE SEVERE PERSONAL INJURY OR DEATH. CALL TECHNICAL SUPPORT AT 866-725-6401 IF YOU HAVE ANY QUESTIONS.

Hardware needed for next step

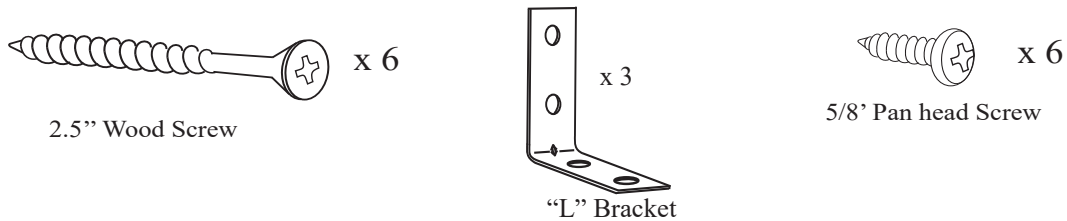

Step 14: Using a Stud Finder locate and mark the studs in your wall behind the Bed Cabinet. Attach "L" brackets to the top, back of the Bed Cabinet using 5/8" Pan Head screws corresponding to where the studs are located in your wall. Now attach the "L" brackets to the studs in the wall using six 2.5" wood screws.

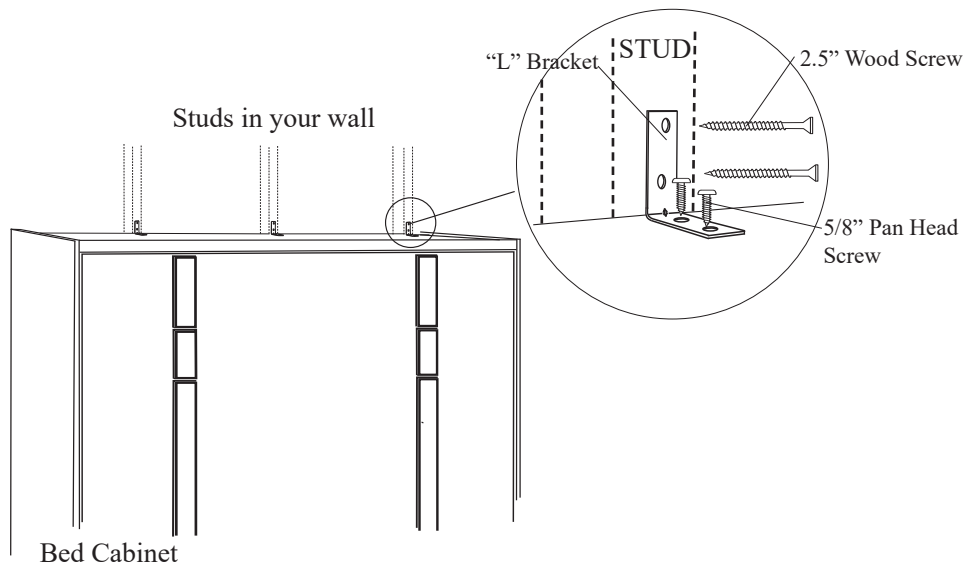

IMPORTANT! Queen and Full size beds require 3 studs, Twin size beds require 2 studs. It is VERY important that the bed cabinet be anchored securely to the wall. For technical support call 866-725-6401 toll free.

Step 15: Open the legs on the front of the bed by gripping the bottom of the leg and lifting them up. THEN REACH YOUR FINGERS INTO THE OPENING UNDER THE LEG AND PULL THE BED TOWARD YOU. Open and close the bed a couple of times so the bed will align. You don't need to lower the bed all the way to the floor, just open it about as illustrated.

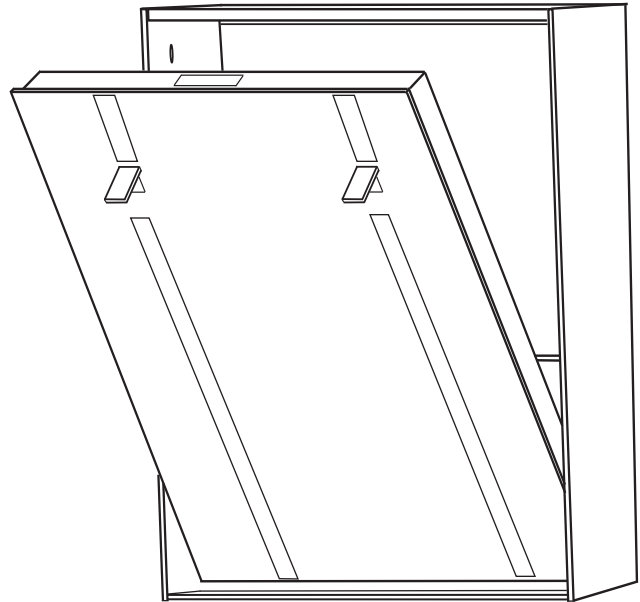

Step 16: Check the gap alignment again. If it looks correct skip this step. If the gap is not correct, meaning that the Bed Front is too close to the Side Board or even touching it at the top on one side. It can be adjusted after the Bed unit is attached to the wall but it will require two people. The procedure will require the bottom of the bed to be moved slightly to the left or right depending on which top corner is too close. If the bed is too close on the top right side for instance the right side (bottom) will need to be slid to the left slightly. Have one person push the bed at the bottom while the second person pulls on the opposite bottom side.

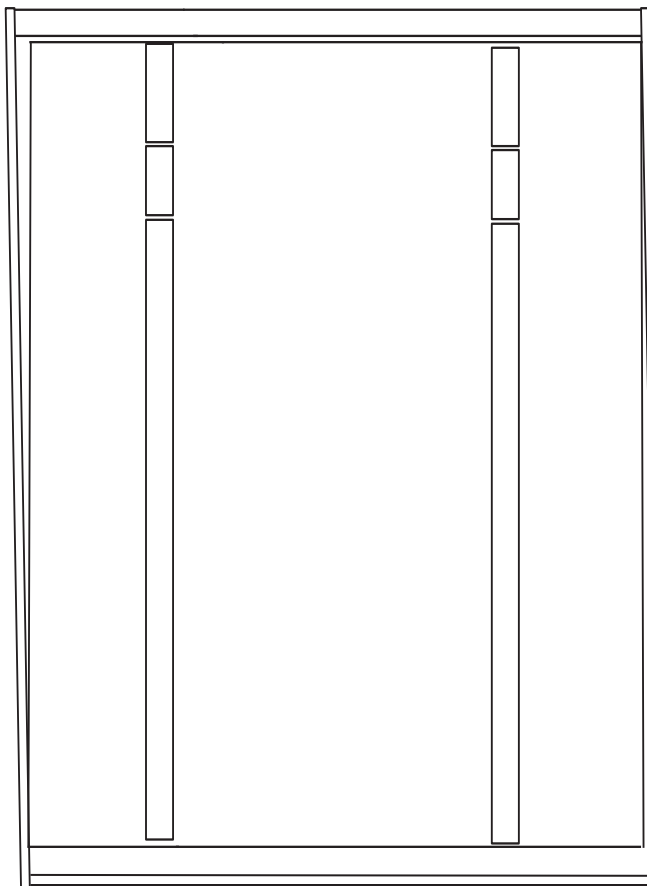

← Push bed over at bottom to align

Tool needed for next step

(not included)



3/16" wood drill bit

Step 17: Anchor the Side Cabinet to the Bed by first pre-drilling three 3/16" holes at the inside edge of the Side Cabinet. Holes should be close to the front edge of the Side Cabinet just behind the Face Frame. One hole near the top, one inside the drawer area (remove drawer from the cabinet to get to this one), and the third should be at the bottom (open door if your cabinet has door, or remove drawer at bottom) for this hole.

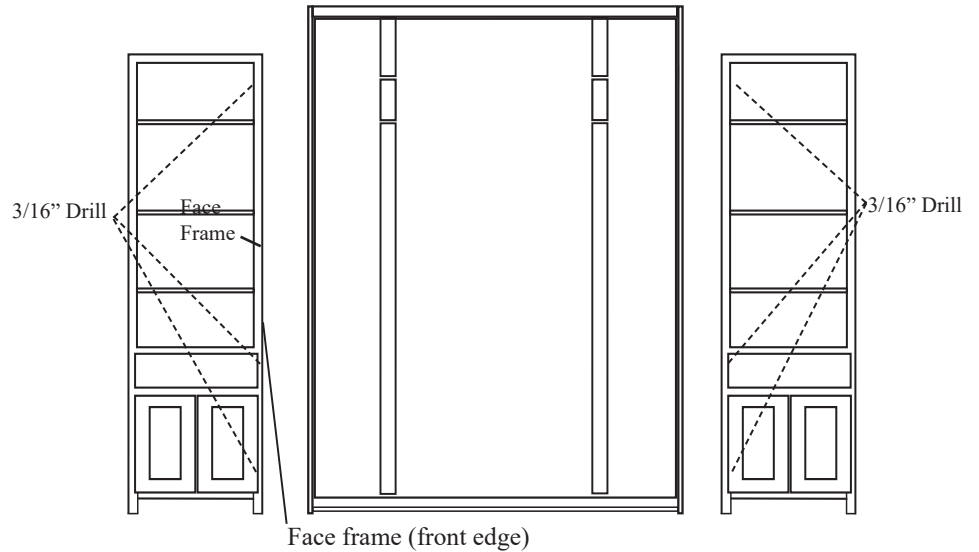

Hardware needed for next step



1 1/4" Wood Screw

(located inside cabinet)

Step 18: Move the side cabinets next to the bed unit and use three 1 1/4" wood screws through the pre-drilled holes to anchor the Side Cabinets to the Bed's Side Boards.

